

Installation manual for X2 base 7 v2

Foreword

All operator panels are developed to satisfy the demands of human-machine communication. Built-in functions such as displaying and controlling text, dynamic indication, time channels, alarm and recipe handling are included.

The operator panel works primarily in an object-oriented way, making it easy to understand and use. Configuration is carried out on a PC using iX Developer software. The project can then be transferred and stored in the operator panel itself.

Various types of automation equipment such as PLCs, servos or drives can be connected to the operator panels. In this manual, the term “the controller” refers to the connected equipment.

This manual explains how to install the operator panel. Please refer to the iX Developer reference manual for further information.

Order no: MAEN329

Copyright © 2021-05 Beijer Electronics AB. All rights reserved.

The information in this document is subject to change without notice and is provided as available at the time of printing. Beijer Electronics AB, including all its group companies, reserves the right to change any information without updating this publication. Beijer Electronics AB, including all its group companies, assumes no responsibility for any errors that may appear in this document. Read the entire installation manual prior to installing and using this equipment. Only qualified personnel may install, operate or repair this equipment. Beijer Electronics AB, including all its group companies, are not responsible for modified, altered or renovated equipment. Because the equipment has a wide range of applications, users must acquire the appropriate knowledge to use the equipment properly in their specific applications. Persons responsible for the application and the equipment must themselves ensure that each application is in compliance with all relevant requirements, standards and legislation in respect to configuration and safety. Only parts and accessories manufactured according to specifications set by Beijer Electronics AB, including all its group companies, may be used.

BEIJER ELECTRONICS AB, INCLUDING ALL ITS GROUP COMPANIES, SHALL NOT BE LIABLE TO ANYONE FOR ANY DIRECT, INDIRECT, SPECIAL, INCIDENTAL OR CONSEQUENTIAL DAMAGES RESULTING FROM THE INSTALLATION, USE OR REPAIR OF THIS EQUIPMENT, WHETHER ARISING IN TORT, CONTRACT, OR OTHERWISE. BUYER'S SOLE REMEDY SHALL BE THE REPAIR, REPLACEMENT, OR REFUND OF PURCHASE PRICE, AND THE CHOICE OF THE APPLICABLE REMEDY SHALL BE AT THE SOLE DISCRETION OF BEIJER ELECTRONICS AB, INCLUDING ALL ITS GROUP COMPANIES.

Contents

1	Safety Precautions	4
1.1	General	4
1.2	Hazardous Materials	4
1.3	Disposal Requirements Under WEEE Regulations	5
1.4	During Installation	5
1.5	During Use	5
1.6	Service and Maintenance	5
1.6.1	Cleaning the Display	5
1.7	Dismantling and Scrapping	6
1.8	Appearance of Air in Touch Screen	6
2	Naming Convention	7
3	Installation	8
3.1	Space Requirements	8
3.2	Installation Process	8
3.2.1	Connections to the Controller	9
3.2.2	Other Connections and Peripherals	10
3.2.3	Open Ports	10
4	Technical Data	11
5	Chemical Resistance	13
5.1	Touch Screen and Overlay Material	13
5.1.1	Protective Film	13
5.1.2	Touch Screen Surface	14
5.1.3	Touch Screen Protector	14
6	Operator Panel Drawings	15
6.1	Connectors	15
6.2	X2 base 7 v2 Outline	17
7	Additional Installation Tips	19
7.1	Grounding the operator panel	19
7.2	Ethernet Connection in the Operator Panel	20
7.3	To Achieve Better EMC Protection	21
7.4	Ambient Temperature	22
7.5	Safety	24
7.6	Galvanic Isolation	25
7.7	Cable and Bus Termination RS-485	27
7.8	USB Memory stick	27

1 Safety Precautions

Both the installer and the owner and/or operator of the operator panel must read and understand this installation manual.

1.1 General

- Read the safety precautions carefully.
- Check the delivery for transportation damage. If damage is found, notify the supplier as soon as possible.
- Do not use the operator panel in an environment with high explosive hazards.
- The supplier is not responsible for modified, altered or reconstructed equipment.
- Use only parts and accessories manufactured according to specifications of the supplier.
- Read the installation and operating instructions carefully before installing, using or repairing the operator panel.
- Never allow fluids, metal filings or wiring debris to enter any openings in the operator panel. This may cause fire or electrical shock.
- Only qualified personnel may operate the operator panel.
- Storing the operator panel where the temperature is lower/higher than recommended in this manual can cause the LCD display liquid to congeal/become isotropic.
- The LCD display liquid contains a powerful irritant. In case of skin contact, wash immediately with plenty of water. In case of eye contact, hold the eye open, flush with plenty of water and get medical attention.
- The figures in this manual serve an illustrative purpose. Because of the many variables associated with any particular installation, the supplier cannot assume responsibility for actual use based on the figures.
- The supplier neither guarantees that the operator panel is suitable for your particular application, nor assumes responsibility for your product design, installation or operation.
- It is recommended to turn on and shut down the operator panel at least once before installing any components/cards or before connecting the operator panel to external devices; for example serial devices.
- For Marine panels only:
 - The operator panel must be installed and operated as described in this document to meet this certification.
 - Observe precautions for handling electrostatic discharge sensitive devices

1.2 Hazardous Materials

Part description 零件描述	Toxic and hazardous materials or elements 有毒和有害的材料或元素					
	Pb	Hg	Cd	Cr6+	PBB	PBDE
PCB and electronic components PCB 和 电子元件	X	0	0	0	0	0

1.3 Disposal Requirements Under WEEE Regulations

For professional users in the European Union: If you wish to discard electrical and electronic equipment (EEE), please contact your dealer or supplier for further information.

For disposal in countries outside of the European Union: If you wish to discard this product please contact your local authorities or dealer and ask for the correct method of disposal.

1.4 During Installation

- Install the operator panel according to the accompanying installation instructions.
- Ground the operator panel according to the accompanying installation instructions.
- Only qualified personnel may install the operator panel.
- Separate the high voltage, signal, and supply cables.
- Make sure that the voltage and polarity of the power source is correct before connecting the operator panel to the power outlet.
- Peripheral equipment must be appropriate for the application and location.

1.5 During Use

- Keep the operator panel clean.
- Emergency stop and other safety functions may not be controlled from the operator panel.
- Do not use excessive force or sharp objects when operating the touch screen.

1.6 Service and Maintenance

- Only qualified personnel should carry out repairs.
- The agreed warranty applies.
- Before carrying out any cleaning or maintenance operations, disconnect the equipment from the electrical supply.
- Clean the display and surrounding front cover with a soft cloth and mild detergent.

1.6.1 Cleaning the Display

We recommend using a dry, clean cloth to wipe off dust regularly. Use alcohol or ammonia-based cleaning agent for cleaning only when necessary. When other solvents or cleaning agents are used, be sure to follow manufacturers' instructions.

The agent should be applied to a clean cloth and should not be sprayed directly onto the panel surface. After cleaning the agent should be removed.

Ammonia based glass cleaners (typically 5-10% ammonia) or 75% alcohol can be used to clean the surface of PCAP and resistive touch panels.

When you clean the surface of your touch panel, please follow these steps:

1. Apply cleaning agent (alcohol, bleach, or glass cleaner) to a clean cloth. Make sure the cloth is well saturated.
2. Wipe touch panel in a “Z” motion on the touch panel surface.
3. Dry the panel thoroughly with a dry cloth, removing as much of the cleaning solution as possible.
4. Do not mix bleach and ammonia because this will produce a dangerous chemical reaction.
5. Please do not spray cleaning solution directly onto the touch panel surface.

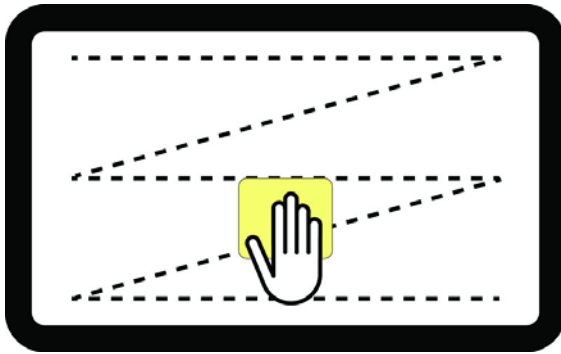

Note:

- Cleaning solutions containing bleach, alcohol, and ammonia are corrosive to touch panel surface coatings and ITO film. So, you should not leave the solution on the touch panel surface for more than 2 minutes. Make sure to remove all residue when finished cleaning.
 - Do not use sharp tools to clean the surface of the touchscreen.
 - Do not use air guns, water jets, or steam, to clean the surface of touchscreens as they may damage touchscreen functionality.
 - If condiments, food, or drinks are spilled on the surface of the touchscreen, please remove them immediately.
 - Ensure moisture does not seep through the cable connection area from the edges during cleaning.
-

1.7 Dismantling and Scrapping

- The operator panel or parts thereof shall be recycled according to local regulations.
- The following components contain substances that might be hazardous to health and the environment: lithium battery, electrolytic capacitor, and display.

1.8 Appearance of Air in Touch Screen

The layer structure of the touch screen contains air. In rare cases, the appearance of bubbles can arise. This is purely cosmetic and does not affect the functionality of the operator panel. The appearance can occur under certain environmental conditions such as temperature, humidity, and atmospheric pressure.

2 Naming Convention

The name of each panel is based on its properties according to the table below.

X2 family	Size (inches)	Generation/Version	Variant	
base	4	v2	SC	SoftControl
pro	5		SM	SoftMotion
marine (= with BL)	7		HB	High Brightness
	10		HP	High performance
control (= with SC)	12		BL	Black
	15		12V	12 Volt
motion (= with SM)	21		SL	Sealed
			RO	Rugged Only
extreme			CO	Certification Only
			web	

Examples:

- X2 base 5 v2
- X2 pro 7
- X2 control 10
- X2 marine 12 SC
- X2 marine 15 HB SC
- X2 extreme 7 12V*
- X2 extreme 12 HP SC*
- X2 extreme 7 SL HP*
- X2 extreme 12 SL HP SC*
- X2 extreme 7 CO*
- X2 extreme 12 SL HP RO

Note:

Not all combinations are available.

Note:

* indicates variants including IECEx\ATEX and C1D2 accreditation.

3 Installation

3.1 Space Requirements

- Maximum installation plate thickness: 4 mm.

The following drawings show the space requirements in millimeters when installing the operator panel. The drawings are only illustrative and may be out of proportion.

3.2 Installation Process

The following is needed:

- A Phillips/slot screwdriver

Do the following:

1. Unpack and check the delivery. If damage is found, notify the supplier.

Note:

Place the operator panel on a stable surface during installation. Dropping the operator panel or letting it fall may cause damage.

2. To cut a correct opening for the operator panel, use the cut out dimensions in the outline drawing. A separate cut out drawing is available for download from the Beijer Electronics web site. For more information, see sections [Operator Panel Drawings](#) and [Technical Data](#).
3. Make sure that the mounting surface of the cutout is smooth and cleaned from any burrs or debris.
4. Install the operator panel into the cutout.
5. In cases where the front panel seal is critical, use a torque wrench to ensure all screws are torqued within the specification above.

- Connect the cables in the specified order, according to the drawing and steps below.

Caution:

- The operator panel must be brought to ambient temperature before it is started up. If condensation forms, ensure that the operator panel is dry before connecting it to the power outlet.
- Ensure that the operator panel and the controller system have the same electrical grounding (reference voltage level), otherwise errors in communication may occur.
- Ensure that the voltage and polarity of the power source is correct.
- Separate high voltage cables from signal and supply cables.
- Shielded communication cables are recommended.

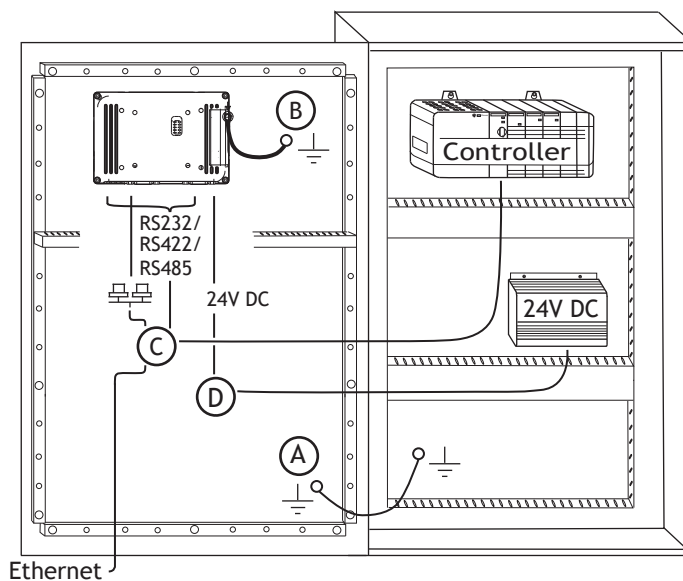

The image is illustrative only and may differ slightly from the actual panel.

- Connect cable A.
 - Connect cable B, using 14-20 AWG (2.08–0.52 mm²), 180–220 N-cm torque.
 - Connect cable C.
 - Connect cable D. The recommended cross-section of the cable is 1.5 mm².
- Carefully remove the protective film over the operator panel display, take care to avoid static electricity that could damage the panel.

3.2.1 Connections to the Controller

For information about the cables to be used when connecting the operator panel to the controller, please refer to the help file for the driver in question.

3.2.2 Other Connections and Peripherals

Cables, peripheral equipment and accessories must be suitable for the application and its environment. For further details or recommendations, please refer to the supplier.

3.2.3 Open Ports

In the firmware there are some ports that are open by default due to the operating system or that the internal application requires it.

Type	Description	Open by default
UDP	Project transfer (9999)	Yes
UDP	Netbios (137)	Yes
UDP	Netbios (138)	No ⁽¹⁾

⁽¹⁾ Filtered.

4 Technical Data

Parameter	X2 base 7 v2
Front panel, W × H × D	202x152x37 mm
Cut out dimensions, W × H	186x136 (+/-1) mm
Mounting depth	32 mm (132 mm including clearance)
Mounting	Switchboard installation
Front panel seal	IP 65
Rear panel seal	IP 20
Touch screen material	Polyester on glass, ITO film, resistive
Frame overlay	Autoflex EBA 180L
Touch screen operations	1 million finger touch operations
Reverse side material	Plastic
Frame material	Plastic
Weight	0.56 kg
CPU	TI Sitara AM335x Single Core 600MHz, (TI AM3352BZCZ60)
Serial port COMA	Standard DSUB (9-pin, female). 1x RS232 RX/TX with RTS/CTS 1x RS422 or 2x RS485
Serial port COMB	N/A
Serial port COMC	3 pin screw connector 1x RS485
Ethernet LAN A	10/100 Mbit/s. Shielded RJ 45
Ethernet LAN B	N/A
USB-A	1 × USB Host 2.0, max output 500 mA
USB-B	N/A
External storage media	N/A
Flash memory (application memory)	2 GB
Memory RAM	512 MB (DDR3)
NVRAM	N/A
LED	N/A
Real time clock	Yes
Battery	Lithium battery type CR 2032, exchangeable
Power consumption at rated voltage	5.6 W
Fuse	Internal DC fuse, 3 AT, SMD

Parameter	X2 base 7 v2
Power supply	+24 VDC (18-32 V DC) CE: The power supply must conform with the requirements according to EN/IEC 60950 and EN/IEC 61558-2-4. UL and cUL: The power supply must conform with the requirements for class 2 power supplies.
Display	7.0" TFT-LCD with LED backlight. 800x480 pixels, 16M colors
Active area of display, W x H	154.08 x 85.92
Pixel errors	Class I (ISO 9241-307)
Backlight brightness	400 cd/m ²
Backlight lifetime	20000 hours
Operating temperature	0 °C - +50 °C
Storage temperature	-20 °C - +60 °C
Relative humidity in operation	5 - 90% non-condensed /25 °C
Vibration	1g, according to IEC 60068-2-6, Test Fc
Mechanical shock	10g, half-sine, 6ms according to IEC60068-2-27
Approvals and certifications	CE / FCC / KCC Information is available on www.bejerelectronics.com
UL approval	Information is available on http://www.bejerelectronics.com and/or https://UL.com

5 Chemical Resistance

5.1 Touch Screen and Overlay Material

5.1.1 Protective Film

Solvent Resistance

The protective film withstands exposure of more than 24 hours duration under DIN 42 115 Part 2 to the following chemicals without visible change:

Acetonitrile	Diesel	Petroleum spirit ⁽¹⁾
Ajax / Vim in solution	Downy / Lenor ⁽¹⁾	Phosphoric acid (<30%)
Alkalicarbonate solution ⁽¹⁾	Ethanol	Potassium ferricyanide
Ammonia (<40%) ⁽¹⁾	Glycerine	Potassium hydroxide (<30%)
Acetic acid (<50%)	Glycol	Pure Turpentine
Ariel powder in solution ⁽¹⁾	Gumtion ⁽¹⁾	SBP 60/95 ⁽¹⁾
Bleach ⁽¹⁾	Hydrochloric acid (<36%)	Sulfuric acid (<10%)
Castor oil	Linseed oil	Tomato ketchup
Caustic soda (<40%) ⁽¹⁾	Methanol	Trichloroacetic acid (<50%)
Cutting oil	Nitric acid (<10%)	White Spirit
Cyclohexanol	Paraffin oil	Windex ⁽¹⁾
Diacetone alcohol	Persil powder in solution ⁽¹⁾	Wisk

⁽¹⁾ Extremely faint glossing of the texture was noted.

The Autoflex protective film withstands DIN 42 115 Part 2 exposure of up to 1 hour duration to glacial acetic acid without visible change.

The Autoflex protective film is not resistant to high pressure steam at over 100 °C or the following chemicals:

Concentrated mineral acids	Benzyl alcohol
Concentrated caustic solution	Methylene chloride

5.1.2 Touch Screen Surface

The touch screen surface on the operator panel withstands exposure to the following solvents without visible change:

Solvents	Time
Acetone	10 minutes
Isopropanol	10 minutes
Toluene	5 hours

The touch screen surface on the operator panel is made of polyester with a hard coat to resist scratches and withstand exposure to many solvents without visible change.

5.1.3 Touch Screen Protector

For harsh environments and exposure to outdoor conditions, it is recommended to use a protective film to guard the touch screen from damage. This optional part can be ordered from Beijer Electronics.

6 Operator Panel Drawings

6.1 Connectors

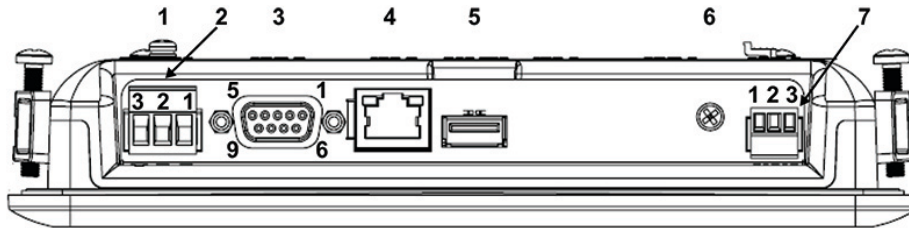

Pos	Connector	Description
1	Ground screw	Screw to connect functional ground
2	Power supply	3-pin screw connector, +24V DC (18-32V DC)
3	COM-A	DSUB (9-pin, female), serial communication port
4	LAN-A	RJ 45 (shielded), 10/100Mbit
5	USB-A	USB 2.0 Host, max output current 500 mA
6	COM-C screw	Screw to connect COM-C cable shield
7	COM-C	3-pin screw connector

COM-A			
Serial port pin assignment			
Pin	COM 1	COM 2	COM 3
1		RS422 TX+ or RS485 Tx+/Rx+	
2	RS232 RxD		
3	RS232 TxD		
4		RS422 RX+	RS485 Tx+/Rx+
5	GND	GND	GND
6		RS422 TX- or RS485 Tx-/Rx-	
7	RS232 RTS		
8	RS232 CTS		
9		RS422 RX-	RS485 Tx+/Rx-

The connector supports up to three independent serial communication channels and can be configured for RS-232 and RS-422 or 2×RS-485.

COM-C			
Serial port pin assignment			
Pin	COM 6		
1	GND		
2	RS485 Tx+/Rx+		
3	RS485 Tx-/Rx-		

6.2 X2 base 7 v2 Outline

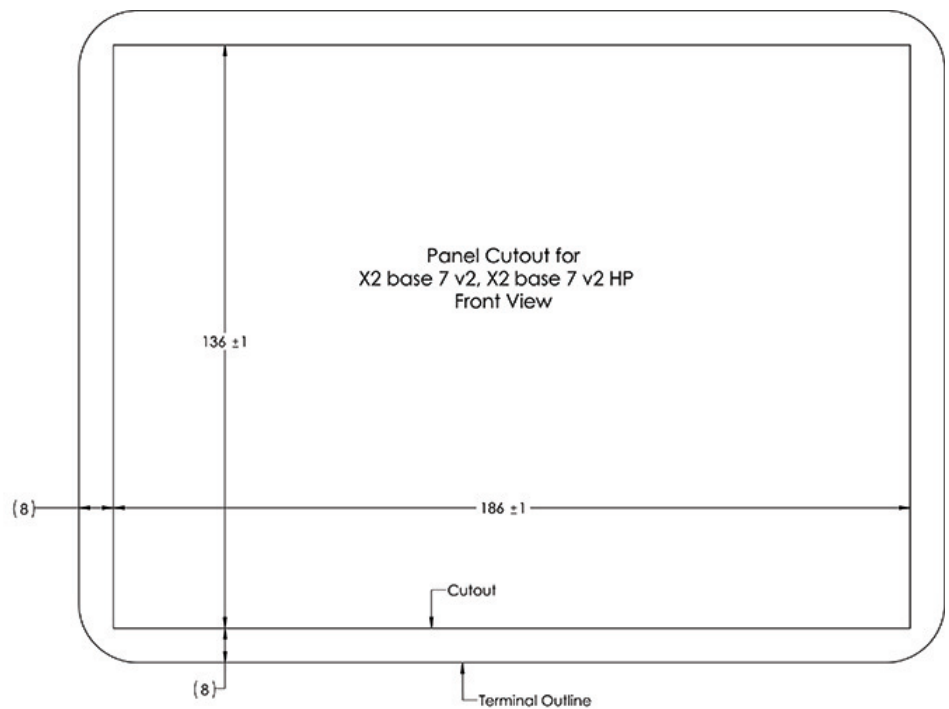
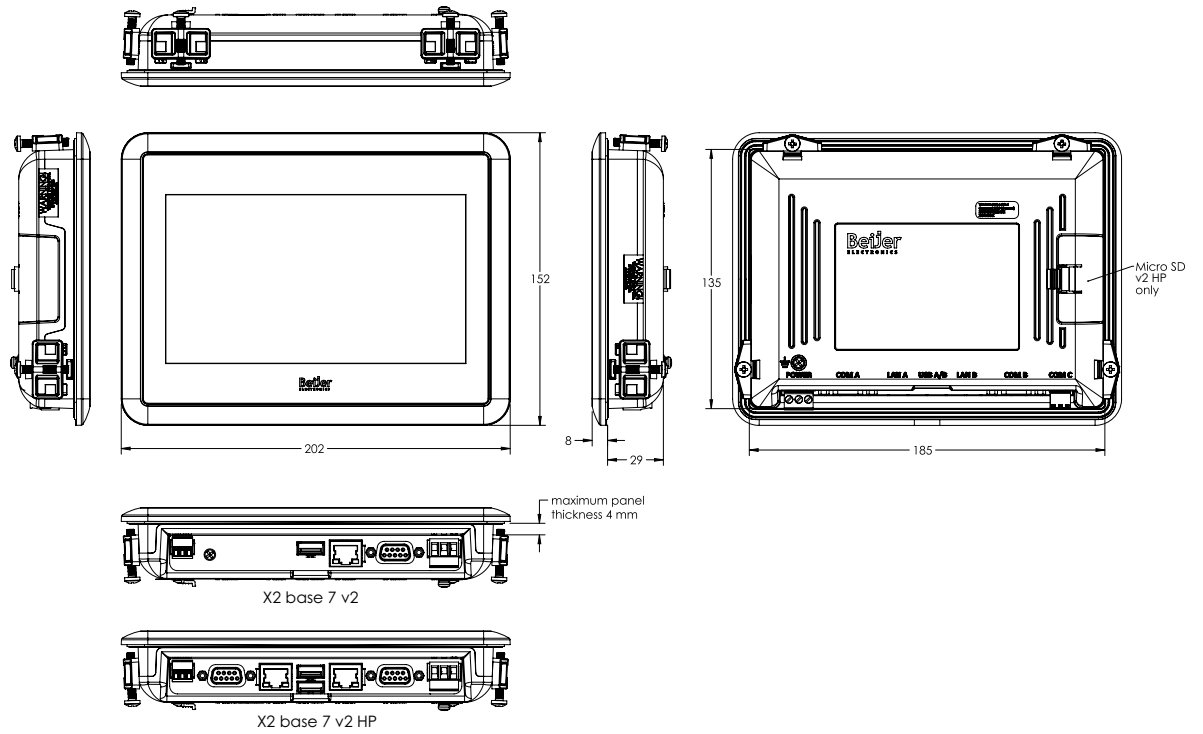

Note:
Minimum thickness for the front plate is 2.0 mm.

Note:

A Step CAD file is available on the web site www.bejerelectronics.com

7 Additional Installation Tips

When experiencing communication problems in noisy environments or when operating close to temperature limits, the following recommendations are to be noticed.

7.1 Grounding the operator panel

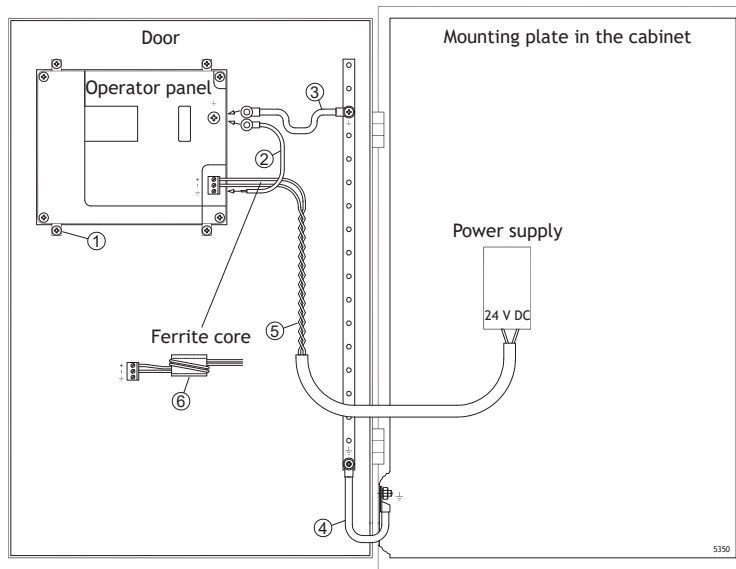

The mounting clamps of the operator panel do not provide a secure grounding connection between the panel and the device cabinet, see 1 in drawing above.

1. Connect a wire, that is sized correctly according to local electrical codes, between the quick-connect terminal connector on the operator panel and the chassis of the panel, see 2 in drawing above.
2. Connect a wire or grounding braid, that is sized correctly according to local electrical codes, between the chassis of the operator panel and the closest grounding point on the door, see 3 in drawing above.
3. Connect a strong but short grounding braid between the door and the device cabinet, see 4 in drawing above.
4. Twist the cables onto the 24 V DC feed, see 5 in drawing above.
 - 2 turns around the ferrite core provide 4 times the suppression of 1 turn.
 - 3 turns around the ferrite core provide 9 times the suppression of 1 turn.

Connect a wire or grounding braid, that is sized correctly according to local electrical codes, between the chassis of the operator panel and the closest grounding point.

Note:

The grounding wires should be short and the conductor should have a large area. A long, thin grounding wire has a very high impedance (resistance) at high frequencies and does not guide disturbances to the ground.

Multi-wire conductors are better than single wire conductors with the same area.

A braided conductor wire with the same area is even better. The best is a short, thick grounding braid.

7.2 Ethernet Connection in the Operator Panel

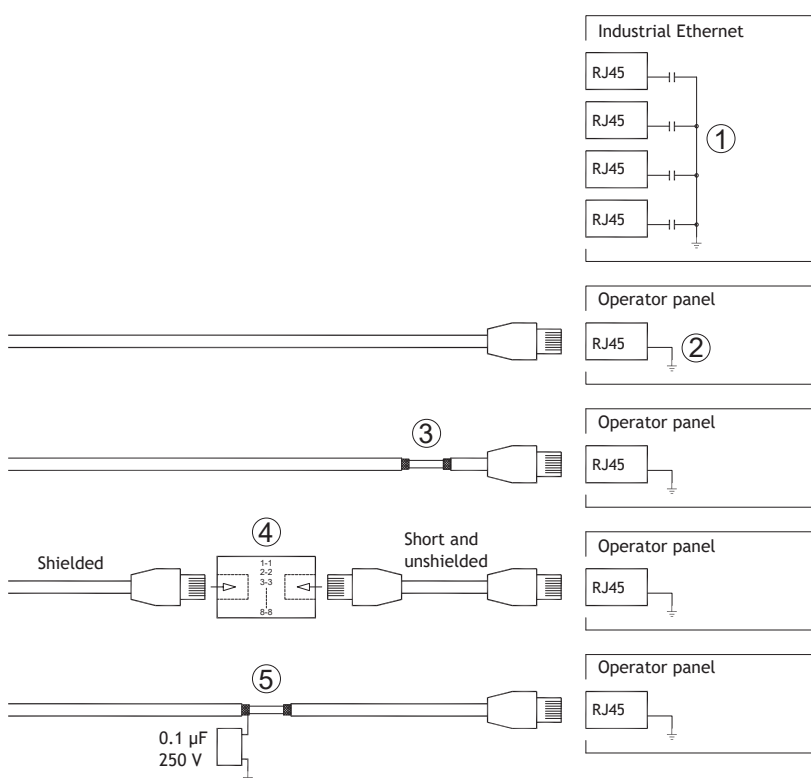

In some industrial units for Ethernet, the RJ45 contact's shield is connected to the chassis via a capacitor, see 1 in drawing above.

The operator panel's Ethernet shield is directly connected to the chassis, see 2 in drawing above.

1. Check whether the other Ethernet unit has its shield directly grounded or grounded via a capacitor.

Note:

In many cases, connecting the shielded Ethernet cabling to the chassis at both ends is inappropriate. Hum or grounding loops can occur. Unshielded cabling may even result in fewer communication errors.

A good solution may be to use a shielded Ethernet cable, but to connect the shield at one end only.

One option is to break the shield, see 3 in drawing above.

A more elegant method is to expand the shielded Ethernet cabling with a piece of unshielded Ethernet cable, see 4 in drawing above.

The shield can be grounded via an external $0.1 \mu\text{F}/250 \text{ V}$ film capacitor, see 5 in drawing above. This connects the HF transients to ground.

7.3 To Achieve Better EMC Protection

- Initially, use the original cabling from Beijer Electronics primarily.
- Place the 24 V DC and communications cabling in one cable trunk/cable duct and 230/380 V AC in another. If the cables need to be crossed, cross them at 90° only. Avoid combining the cabling for stronger 24 V DC outputs with the communication cabling.
- Initially, use the original cabling from Beijer Electronics primarily.
- Use shielded cables for RS-232 communication.
- Use twisted pair and shielded cabling for RS-422 and RS-485.
- Use the cabling intended for the bus type; Ethernet, Profibus, CC-Link, CAN, Device Net etc.
- Use the cabling intended for the bus type; Ethernet and CAN
- Install and connect according to applicable specifications for the relevant bus standard.
- Use shielded cabling for Ethernet, preferably with foil and a braided shield.
- D-sub covers should be shielded, and the shield should be connected to the cover 360° where the cable enters.
- Connect the shield at both ends.

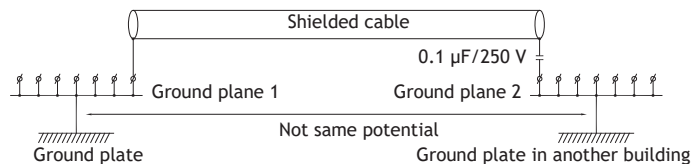

With longer distances, there is a risk that the ground potential may be different. In that case, the shield should only be connected at one end. A good alternative is to connect the other end of the shield to the ground via a $0.1 \mu\text{F}/250 \text{ V}$ film capacitor. Both ends are then connected to the ground in terms of HF, but only connected to the ground at one end in terms of LF, thus avoiding the 50/60 Hz grounding loops.

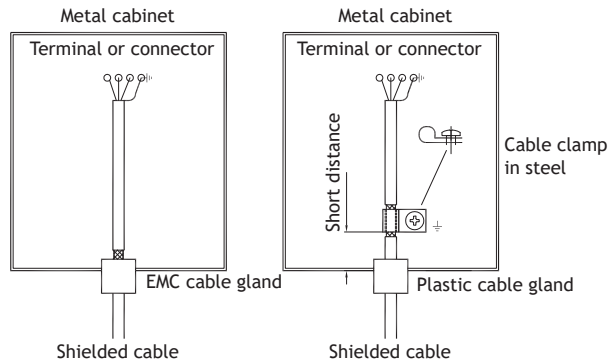

1. Use an EMC cable gland or regular plastic cable gland, remove the outer jacket and connect the shield to the installation plate with a 360° metal cable clamp.
2. Place the 24 V DC and communications cabling in one cable trunk/cable duct and 230/380 V AC in another. If the cables need to be crossed, cross them at 90° only. Avoid combining the cabling for stronger 24 V DC outputs with the communication cabling.

Ferrite cores that are snapped onto the shielded cabling may remove minor disturbances. Large ferrite pieces that are snapped onto unshielded cabling and where the wires go 2-4 times around the cores are approximately 5-25 times more efficient.

7.4 Ambient Temperature

The maximum ambient temperature for the operator panel is provided in the specifications. The ambient temperature refers to the temperature in the device cabinet which cools the operator panel's electronics.

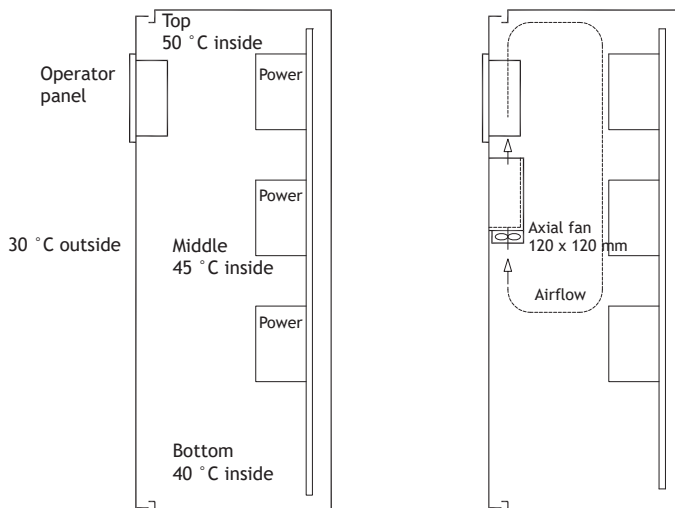

In most cases, the ambient temperature for the operator panel is significantly higher than the device cabinet's ambient temperature.

If the cabinet is tall and there are a number of heat-generating devices, the temperature at the top of the cabinet is considerably higher than the temperature

increase that would be expected. All electronics are sensitive to heat. The lifespan of an electrolytic capacitor is cut in half with an 8-10 °C increase in temperature. A 15-20 °C temperature increase results in a quarter of the lifespan etc.

Rittal has a good program for estimating the anticipated average temperature in the cabinet as well as a large program for controlling the temperature in the device cabinet.

An enamel-coated steel cabinet has a radiant heat value of 5.5 W/m² per degrees C.

Installing a fan inside the cabinet evens out the temperature, while moving air provides considerably better cooling than still air.

Install the fan so that it sits in a cooler area and blows cold air against the operator panel. If the fan is mounted at the top and sucks warm air upwards, the ambient temperature of the fan becomes higher, resulting in a shorter lifespan.

An approximate value of the net power consumption for the operator panel can be calculated by multiplying the supply voltage with the current drawn by the operator panel. This is assuming that all supplied power is transformed to heat.

Note:

Please ensure that the temperature will not exceed the maximum ambient operating temperature in the enclosure. This can be influenced by other heat generating devices.

7.5 Safety

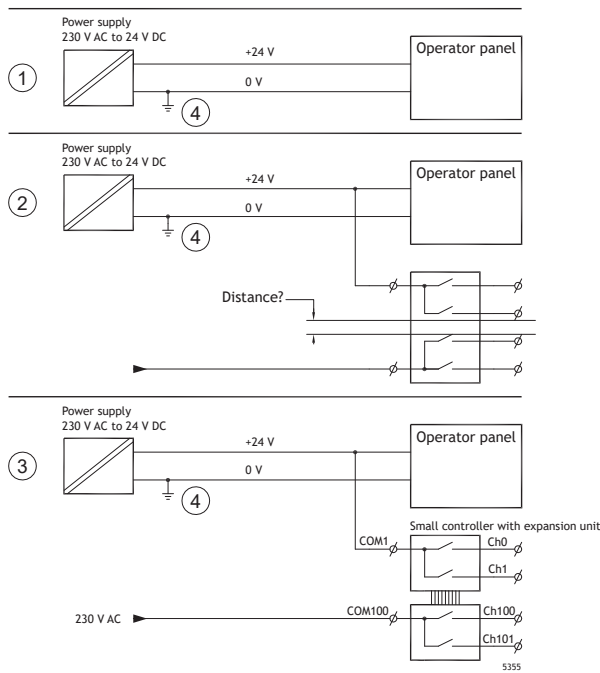

If a power supply that meets safety standards is used and only powers the operator panel, there is no problem. See 1 in drawing above.

However, if a 24 V unit that also powers other units is used, there is reason to be cautious, see 2 in drawing above. The operator panel does not have insulation that meets safety requirements in the event of a potential short circuit between 230 V AC and 24 V DC. It is assumed that the 24 V power supply is secure, for example, SELV according to EN 60950 (protection against electric shock) and UL 950.

Note:

Here is an example that explains why a secure 24 V DC power supply can be ruined by mixing 24 V relay contacts with 230 V AC relay contacts in a smaller controller. Check that the clearances and creepage distances between 24 V DC and 230 V AC fulfill EN 60950 or UL 950. If not, input a separate 24 V unit into the operator panel.

If there is a substantial distance between the relay contacts for 24 V DC and 230 V AC, it is OK to use the same 24 V devices for all feeds. See 3 in drawing above.

Connect 0 V on the 24 V power supply to the ground, see 4 in drawing above. This offers three advantages:

- Safety is increased. The 24 V power supply is not live in the event of a faulty connection or short circuit between 0 V (24 V) and 230 V phase.
- Transients on the 24 V feed are connected to the ground.
- No risk that the 24 V feed is at a high level in relationship to the ground. This is not unusual since there is high static electricity.

7.6 Galvanic Isolation

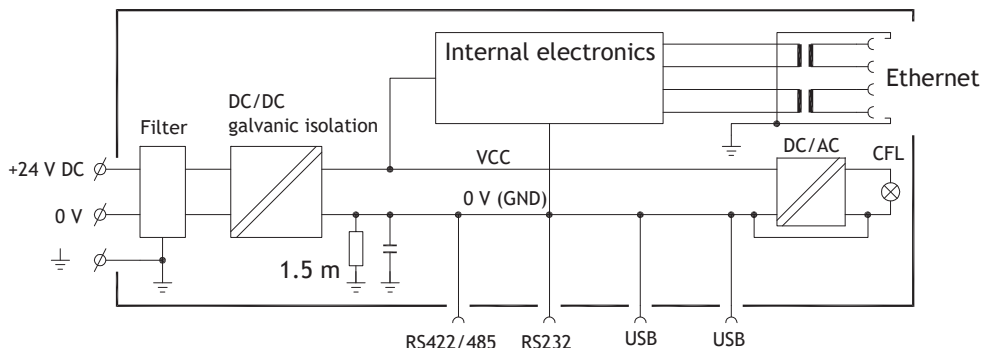
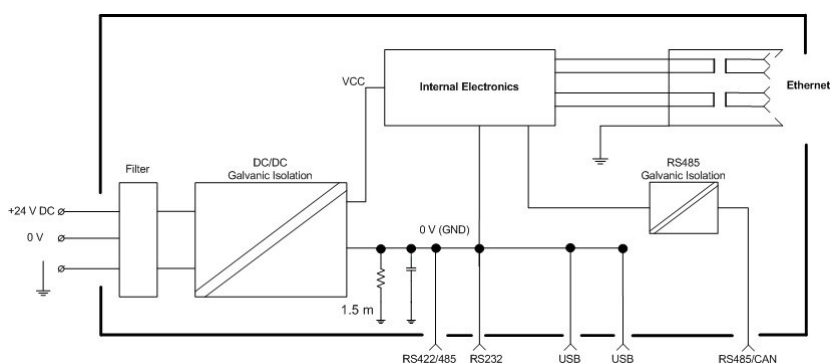
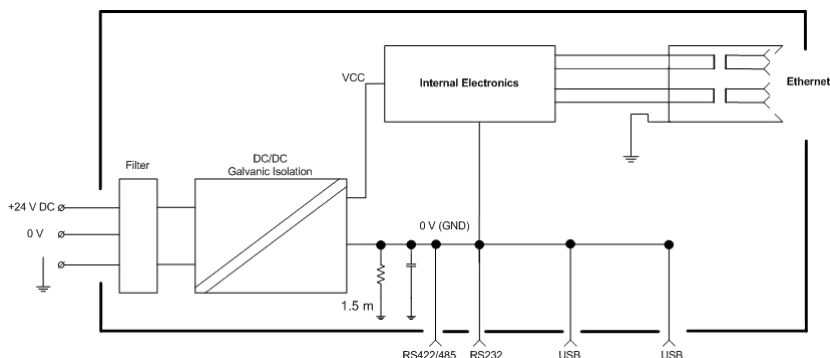

The operator panel has galvanic isolation against the 24 V DC power supply but no galvanic isolation between the communication ports for RS-232, RS-422/RS-485 and USB. Only the Ethernet connection has galvanic isolation.

The operator panel has galvanic isolation against the 24 V DC power supply but no galvanic isolation between the communication ports for RS-232, RS-422/RS-485 and USB. Only the Ethernet- and RS-485 connection have galvanic isolation.

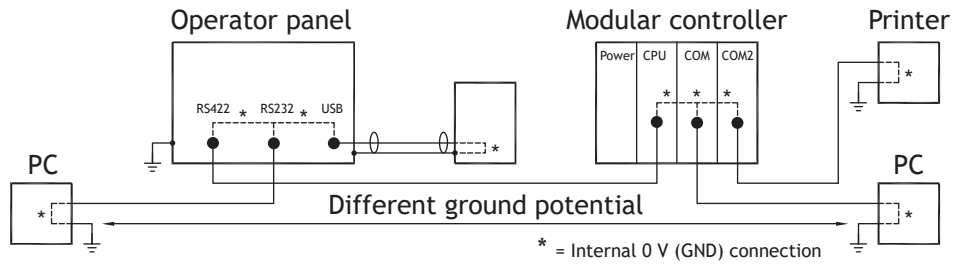

When a PC is connected to the operator panel, the internal 0 V (GND) of the panel is connected to the protective ground via the PC.

A number of USB devices can have the shield connected together with the protective ground. Here, the 0 V (GND) of the operator panel is connected to the protective ground when, for example, a USB memory stick, keyboard, or similar device is plugged in.

If a number of units are connected that have a 0 V and a ground connection, and these are connected to various grounding points, there is a substantial risk of problems. Grounding currents go through communication cables, the rear plate of the controller, internally in the operator panel, and can cause errors.

Use external units to improve communication and achieve galvanic isolation. Westermo has good industry-standard insulators that are also insulated from the 24 V DC feed.

Note:

It is very important to make sure that the 24 V feed in the external insulation unit is not connected to one of the communication outlets. If it does not have 100% insulation against the 24 V feed, disturbances and grounding currents from the 0 V on the 24 V side disrupt the communication.

Using this type of unit solves one problem but creates a larger problem! A substandard installation may work now, but problems may arise when other devices are connected.

7.7 Cable and Bus Termination RS-485

- If maximum transfer distance and maximum transfer speed is needed, shielded and twisted pair cable should be used. The mutual capacitance may not exceed 52.5 pF/m, and the cable area should be at least 0.25 mm² (AWG 24).
- 0 V, the reference voltage for communication should be included in the cabling. With two-way communication use two pairs; one pair for communication and one pair for 0 V.
- The shield must be grounded at one end. The other end is usually grounded, but with longer distances or when there is a difference in the ground potential, the shield should be connected to the ground via 0.1 µF/250 V film capacitor to prevent ground current in the braided shield. A number of manufacturers recommend that the shield be grounded at each node. Various manufacturers have different systems for bus termination.

Depending on the recipients' design, the bus wires may be on the same level or require pull-up or pull-down to ensure that no faulty signals are detected when the bus is in resting mode (all transmitters are disconnected).

7.8 USB Memory stick

The USB ports on X2 base v2 are of 2.0 standard. Even though USB 3.0 may work well, we recommend to use USB memory sticks dedicated for USB 2.0.

Beijer

ELECTRONICS

Head office

Beijer Electronics AB

Box 426

201 24 Malmö, Sweden

www.beijerelectronics.com / +46 40 358600