

Operating Instructions “AKKUTEK 2410”

(NBPA 2410-N33G1)

Placing in operation and maintenance only by suitably qualified personnel!

The operating instructions are to be read prior to usage or installation of the **AKKUTEK**, the information given is to be observed! In the case of failure to observe the information given, all rights under the warranty may be lost!

Safety Instructions



- ◆ Power supply for protection class I and enclosure rating IP20. Operation only in dry rooms
- ◆ Observe applicable VDE regulations, in particular VDE 0100 and EN 60204!
- ◆ In front of the unit, a separation must be installed at the input side
- ◆ To switch the unit at the output side voltage free, both energy sources (mains and battery) must be separated.
- ◆ The surrounding air temperature range is to be observed!
- ◆ To prevent overload of the DC output circuit, the circuit is to be protected externally with a fuse! (Value see Section 3.1)
- ◆ Only the battery types specified for the unit are permitted to be used!
- ◆ Battery replacement is only to be made with the unit unpowered! (See Section 10)
- ◆ On the connection of external backup batteries, battery protection must be provided by the user! In this case the protection components (overload and short circuit protection!) must be installed as close as possible to the set of batteries for safety reasons
- ◆ On the usage of batteries, sufficient air flow in accordance with VDE 0510, part 2 must be ensured.
- ◆ Never connect together new and used batteries, or batteries of different types, or from different manufacturers!
- ◆ Dispose of used batteries in an environmentally responsible manner!

1. Concise Description

The battery backed up DC power supply in the **AKKUTEK** range uses the standby-parallel principle of operation and, in conjunction with a lead accumulator, ensures that the DC power supply is reliably maintained in the case of a mains power failure.

The power supply has the following features:

- Switched primary, switched power supply with I/V charging characteristic
- Active power factor correction (PFC)
- Microcontroller-based battery management
- Temperature compensation for charging voltage by means of external sensor module (optional module)
- Display and control panel for switch cupboard door installation or surface mounting (option)

As standard the following equipment versions are available.

Equipment Designation	Comments	Art. No.	Nominal Input Voltage	Nominal Output Voltage
NBPA 2410-0 N33G1M01	Standard unit, individual module	81440.6	230V AC	24V DC
NBPA 2410-0 N33G1S01	Special parameter settings, individual module	NBPCN33G1S01	230V AC	24V DC
NBPC 2410-4 N33G1M03	Standard unit on mounting plate, 4 Ah	NBPCN33G1M03	230V AC	24V DC
NBPC 2410-7 N33G1M01	Standard unit on mounting plate, 7 Ah	NBPCN33G1M01	230V AC	24V DC
NBPC 2410-12 N33G1M02	Standard unit on mounting plate, 12 Ah	NBPCN33G1M02	230V AC	24V DC

2. Standards and Regulations

Safety of power transformers, power supply units and similar Particular requirements for transformers for switch mode power supplies	EN61558 2-17 (VDE 0570 2-17)
Optocouplers for protective separation against electric shock, requirements - tests	VDE 0884
EMC	EN 55011 / 1998 limit class B EN 61000-3-2 and EN61000-3-3 limit class A EN50082-2 / 1995
Overall unit	EN 50178 / EN 60950

3.1 Electrical Data

Rated Input Voltage	230V AC 47-63Hz
Input Voltage Range age	195,5V – 253V 230 V AC -15% / + 10%
Rated Input Current 2410	1.4A
Max. Switch On Current	35A / 2ms
Output Voltage	a) 19.8...26.4V DC b) 19.8..28.6V DC (during activated boost charging or temperature compensation)
Final Charging Voltage	26.4V DC \pm 0.4%
Charging Characteristic	I/V DIN 41773-1
Deep Discharge Protection and Load Shedding at	19.8V DC \pm 0.4%
Nominal Output Current	10A DC
Constant Current Limiting	1.05...1.1xI _{ANom}
Battery Type	Pb battery, maintenance-free
Efficiency 230V Version: U _a =26.4V DC, I _a =20A and U _e =230V AC	88.68%
Max. Power Loss 'worst-case'	44W

Earth Leakage Current	<3.5mA
Fuse Protection, Primary	2.5A slow (internal)
Max. Series Fuse Protection	5A slow
Fuse Protection DC Output Circuit 2410	1) (15A) / 10A slow (external)
Fuse Protection Battery Load Circuit, Secondary 2410	1) (15A) / 10A slow (external)
Type of Connector, Primary 'Netz' (Mains)	Combicon screw terminal 2.5mm ²
Type of Connector, Secondary 'Ua', 'Batt'	Combicon screw terminal 2.5mm ²
Type of Connector, Interface 'IO-1...IO-3'	Combicon screw terminal 1.5mm ²
Type of Connector, Current Share Bus 'CS'	Spring loaded terminal 0.5mm ²

1) If the case of FK2 fuse you have to use the values in brackets

3.2 Indicators

'Netzbetrieb' (Mains Operation)	Green LED, LED illuminates on: • Mains operation, i.e. ($U_E > U_{Emin}$ and $T_{int} < T_{intmax}$)	'Fehler' (Fault)	Red LED LED illuminates on: • Battery operation ('Netzbetrieb' (Mains Operation) LED goes out in this case) • U_A fault • Battery circuit open or high resistance (test interval 60s) • Battery weak • Battery poles reversed • Battery over-temperature (only in conjunction with temperature compensation)
\overline{U}	Green LED (Battery voltage within the monitoring window, i.e. $21.6 < U_{Batt} < 27V$ DC)		
$\frac{\uparrow}{U}$	Green LED (Battery voltage above the monitoring window, i.e. $U_{Batt} = 27V$ DC)		

3.3 Operation

Connection IO-2 (option interface)	External display and control panel for the display of operating parameters and for setting the device parameters (option)
------------------------------------	---

3.4 Signal Inputs and Outputs

'Netzbetrieb' (Mains Operation) ¹⁾	Floating relay contact, normally open, max. contact load 30V DC/ 0.5A
'Fehler' (Fault) ¹⁾	Floating relay contact, changeover, max. contact load 30V DC/ 0.5A
\overline{U} ¹⁾	Floating relay contact, normally open, max. contact load 30 V DC/ 0.5A
$\frac{\uparrow}{U}$ ¹⁾	Floating relay contact, normally open, max. contact load 30 V DC/ 0.5A
Shut-Down	Shut down of the UPS mode Switched input referenced to earth, switching level: 24V DC (16-80V DC)
'Starkladung' (Boost Charging)	Activation of boost charging (boost charging voltage 28.6V DC) Switched input referenced to earth, switching level: 24V DC (16-80V DC)

¹⁾ The signal contacts are coupled to LEDs (see Section 3.2). The illumination of an LED thus results in the energisation of the corresponding relay.

3.5 General

Weight	
a) Individual Module	Approx. 1.6kg
b) Mounting plate version (without batteries)	Approx. 3.0kg
c) 4.0Ah Battery Set	Approx. 5,1kg
d) 7.0Ah Battery Set	Approx. 5.7kg
e) 12.0Ah Battery Set	Approx. 9.2kg
Storage Temperature	Recommended 0...30°C, Permissible 0...50°C
Operating Temperature	Recommended 10...20°C (battery life!),

2410	Permissible 0...40°C
2405	Permissible 0...55°C
Enclosure Rating	IP20
Dimensions	See Section 9

4. Installation

The battery backed up DC power supply is to be installed such that the necessary cooling is provided. A minimum separation of $\geq 75mm$ to neighbouring equipment or assemblies in the area of the ventilation openings is to be maintained. The installation is always to be made such that sufficient air circulation through the unit can be ensured. All fastening points are always to be used to fix the unit. During installation, the unit is to be covered in the case that swarf from drilling can fall on or in the unit. (**Risk of short circuit!**)

5. Connection

Prior to connection, the values for the mains voltage and frequency are to be checked against the values on the rating plate. Connect in accordance with the labels on the connecting terminals. (See main block diagram and connector assignments). Unused connecting terminal screws are to be tightened.

Connection:	Terminal:
Mains Input Voltage	Connecting terminal 'Netz' (Mains) L, N, \perp
DC Output (loads)	Connecting terminal 'Ua' +, -
Pb Battery	Connecting terminal 'Batt' +, -
Battery Temperature Sensor (optional module)	Connecting terminal 'IO-1' 1, 2
Current Share Bus (in case of parallel connection of several modules)	Connecting terminal 'CS' 1
Shut-Down Control Input	Connecting terminal 'IO-1' 3
'Starkladung' (Boost Charging) Control Input	Connecting terminal 'IO-1' 4
Signal Contact 'Fehler' (Fault)	Connecting terminal

(Centralised fault indication)	'IO-1' 5=NC, 6=NO, 7=COM
Signal Contact 'Netzbetrieb' (Mains Operation)	Connecting terminal 'IO-1' 8, 9
Control and Display Panel	Connecting terminal 'IO-2' 1, 2
Battery Current Measurement (optional module)	Connecting terminal 'IO-3' 1, 2
Signal Contact Battery Voltage Above	Connecting terminal 'IO-3' 3, 4
Signal Contact Battery Voltage Within	Connecting terminal 'IO-3' 5, 6



In the case of overload, the DC output current comprises the maximum charging rectifier current as well as the current from the battery. To prevent overload of the DC output circuit, the circuit is to be protected externally ! (Value see Section 3.1)

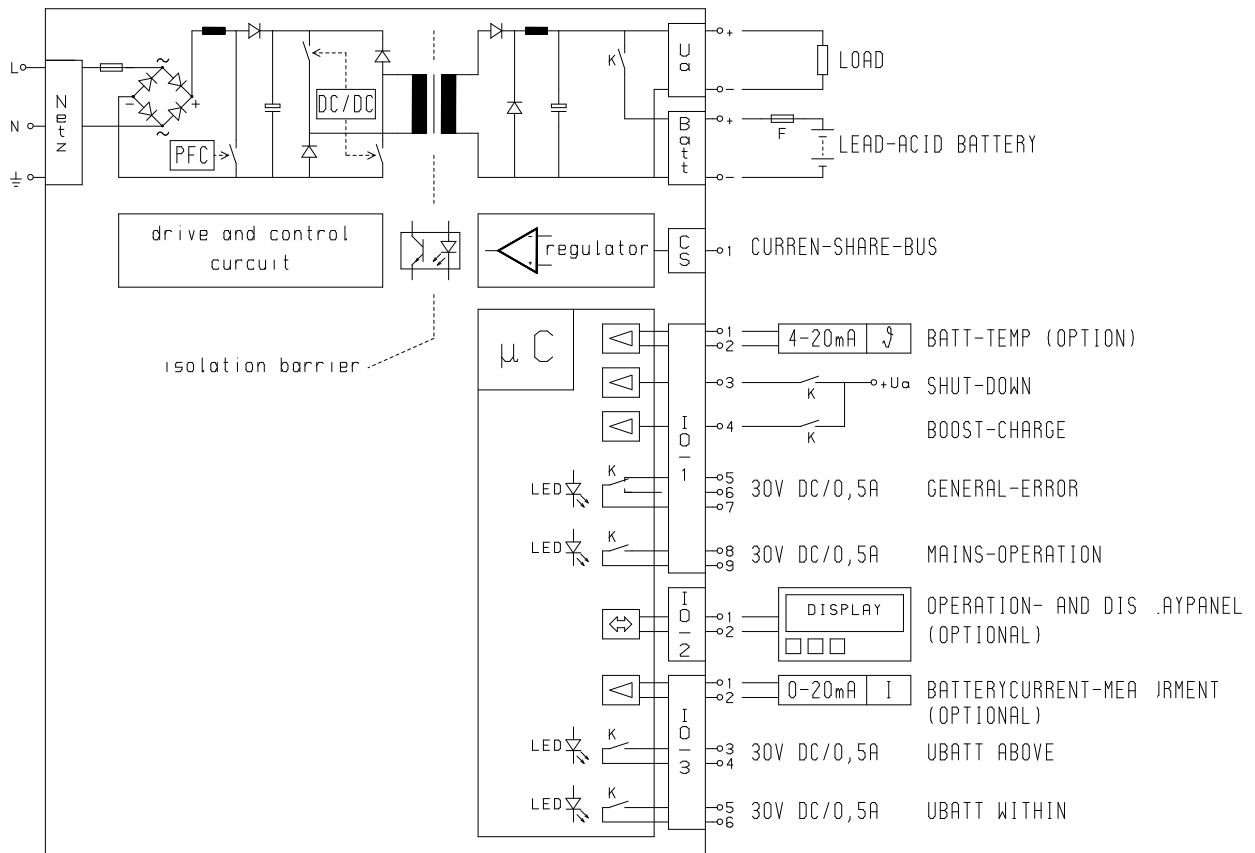

6. Placing In Operation

The unit is switched on by the application of the mains supply.



The battery voltage must match the nominal voltage of the charging rectifier!
Never reverse the poles of the battery!
Never short circuit batteries! Risk of arcing!
Check the connections for correctness prior to switching on for the first time
Only make electrical connections with the unit unpowered

7. Operation

Approx. 2s after the switch on of the mains, the output voltage is enabled and the loads connected supplied with power. The back up battery is also charged. This operating mode is indicated by the illumination of the green n 'Netzbetrieb' (Mains Operation) LED.

By removing the mains voltage, or if the input voltage drops below the minimum, the **AKKUTEK** switches over to battery mode. The battery mode is indicated by the illumination of the 'Fehler' (Fault) LED. The 'Netzbetrieb' (Mains Operation) LED is not illuminated in this case.

The illumination of an LED always results in the energisation of the corresponding signal relay. (See block diagram, Section 5)

The 'Fehler' (Fault) LED has a centralised fault indication function. The individual causes of malfunctions are described in Section 3.2.

7.1 Battery Circuit Monitoring

To check the capability of the UPS to provide back up, the battery circuit is tested cyclically at intervals of 60s; the first test is performed 60s after mains switch on. By means of this test it is possible to identify an open circuit or the high resistivity of the battery circuit. A defective battery circuit is indicated by the simultaneous illumination of the 'Fehler' (Fault) and 'Netzbetrieb' (Mains Operation) LEDs (centralised fault indication)

7.2 Battery Test

During mains operation, a cyclic battery test loads the battery whilst the voltage is measured. In this way it is possible to evaluate the quality of the battery. A seriously aged battery is indicated by the simultaneous illumination of the 'Fehler' (Fault) and 'Netzbetrieb' (Mains Operation) LEDs (centralised fault indication)



The battery test is used to detect seriously aged batteries. To evaluate the backup capacity of the batteries with this system, it is imperative that a manual battery check is performed from time to time! (See Section 11)

7.3 Boost Charging

In exceptional cases, it may be required to boost charge lead batteries. During this process the final charging voltage (and thus also the output voltage!) is increased from 26.4V to 28.6V. Boost charging is activated by applying a +24V DC control voltage to connection 4 on the 'IO-1' terminal strip, and remains activated until the control voltage is removed again.



Boost charging results in the operation of the batteries in the gassing area and can be used to reactivate deep discharged or sulphated batteries. The boost discharge mode should only be used on open, non-maintenance-free batteries and must only be performed for a limited period. The usage of boost charging in conjunction with closed, maintenance-free batteries is not permitted, as here damage can be caused to the batteries!

7.4 Shut-Down

To avoid discharging the backup batteries to the deep discharge limit unnecessarily, it is possible to shut down battery operation early. This is performed by applying a +24V DC control voltage to connection 3 on the 'IO-1' terminal strip.

7.5 Temperature Compensation (optional module)

Lead batteries have a temperature coefficient of approx. $-4\text{mV per }^{\circ}\text{C}$ and cell. The **AKKUTECH** final charging voltage is selected such that battery charging is provided over a temperature range of $15\text{ }^{\circ}\text{C}$ to $-40\text{ }^{\circ}\text{C}$.

In applications with frequent and large temperature variations, the charging voltage should be appropriately compensated to achieve optimal battery life. Also, particularly in the case of very low surrounding air temperature ($T_{\text{u}} < 15\text{ }^{\circ}\text{C}$), compensation should be performed to ensure adequate battery charging.

By connecting the external temperature sensor module (option) to terminal strip 'IO -1' connection 1 and 2 (note poles!), temperature compensation is automatically activated. For an surrounding air temperature variation of $0\text{ }^{\circ}\text{C}$ to $-40\text{ }^{\circ}\text{C}$, the final charging voltage (and thus also the output voltage) varies over a range of 27.3 V DC to 26.2 V DC .

Battery temperatures above $45\text{ }^{\circ}\text{C}$ are indicated by the simultaneous illumination of the 'Fehler' (Fault) and 'Netzbetrieb' (Mains Operation) LEDs

F

To obtain satisfactory battery life, the operating temperature of the batteries should not exceed $20\text{ }^{\circ}\text{C}$. Higher temperatures lead to a drastic reduction in the life!

7.6 Control and Display Panel (optional module, can be connected to AKKUTECH equipment using the option interfaces IO-2 and IO-3)

Particularly in larger battery system, it is often desired to display equipment parameters, e.g. battery voltage, load current, battery current, error messages, etc. and to make parameter settings.

To meet these requirements, a special door mounting display and control panel is available. This panel has an illuminated LC display and a keypad (setting parameters and operation). The panel is connected to the IO -2 interface using two cables.

7.7 Battery Current Measurement (optional module, can be connected to AKKUTECH equipment using the option interfaces IO-2 and IO-3)

To measure the battery current (charging and discharging current), an appropriate current measurement transducer is required that is inserted in the battery cable. With the aid of the Control and Display Panel described in Section 7.6, the battery current can then also be indicated on the display.

8. Taking Out of Operation

The unit is taken out of operation by removing the mains supply. To prevent subsequent backup from the batteries, the battery circuit must be opened by activating 'Shut-Down'. (See Section 7.4) The 'Netzbetrieb' (Mains Operation) and 'Fehler' (Fault) LEDs must go out.



**Never undo electrical connections whilst the unit is in operation!
It also not permitted to make electrical connections whilst the unit is in operation!**

9. Installation Drawings

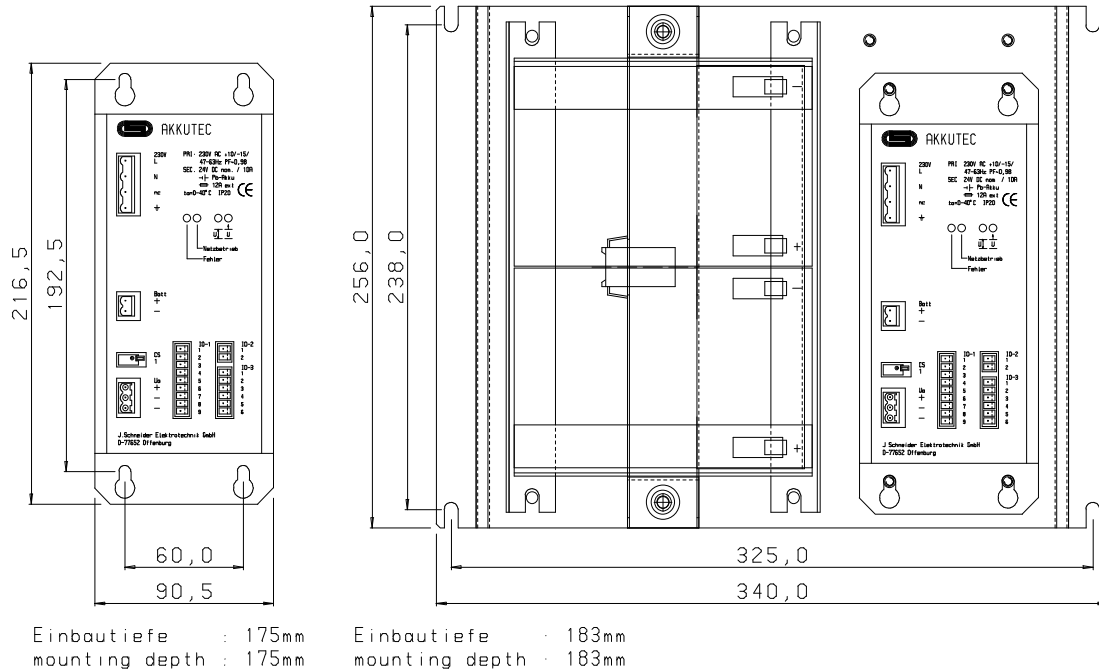

Installation depth not including terminals!

type	high	weith	depth including terminals
with 4 Ah	240 mm	265 mm	200 mm
with 7/ 12Ah	256 mm	340 mm	200 mm

10. Battery Replacement

Battery replacement is only permitted to be performed by authorised service personnel!

Battery replacement is to be performed as follows:

- Battery removal:
- Take out of operation as described in Section 8
 - Remove 3-pin Combicon battery connector on the **AKKUTEK**
 - Undo the 2 fixing bolts on the battery retaining strap, hold battery during this process!
 - Undo electrical connections on battery
 - Remove battery

Battery installation: Installation is performed in the reverse order of removal as described above. It is to be ensured that the battery poles are connected correctly. In the case of batteries connected with the poles reversed, battery charging and battery enable during mains failure is inhibited, this is indicated by the simultaneous illumination of the 'Netzbetrieb' (Mains Operation) and 'Fehler' (Fault) LEDs.



Never short circuit batteries! Risk of arcing and burns!

Never connect together new and used batteries, or batteries of different types, or from different manufacturers!

The correct retention of the batteries is to be checked after refitting!

Used batteries are to be disposed in an environmentally responsible manner!

11. Maintenance

To ensure adequate backup capacity of the power supply, the capacity of the batteries should be checked at regular intervals of 3 to 6 months.

Checking the battery: Force battery operation by switching off the mains. The batteries must achieve the required bridging time under nominal conditions. When the deep discharge limit is reached, the **AKKUTEK** switches off automatically.

The unit is to be cleaned at least once a year, depending on the degree of soiling.

12. Spare Parts

Item	Spare Part	Art. No.
1	Lead Accumulator, Maintenance-Free 12V / 4Ah	452011.42
2	Lead Accumulator, Maintenance-Free 12V / 7Ah	452011.21
3	Lead Accumulator, Maintenance-Free 12V / 12Ah	452011.22
4	15A-FK2 Fuse	42041.6
5	7.5A-FK2 Fuse	42041.4

13. Special Operating Modes

The **AKKUTEK** is suitable for master-slave operation as well as for redundant operation. The required operating mode is defined by the setting of the parameters in the unit and the external circuit (see below).



The parameters in the AKKUTEK units are set with the aid of the Control and Display Panel (optional module) via the IO-2 interface.

If no control panel is available at the user, the modules can also be purchased with the parameters set appropriately in the factory. The parameters set can be seen on the additional label on the front of the module!

13.1 Example Circuit for Master-Slave Operation (Increased Power)

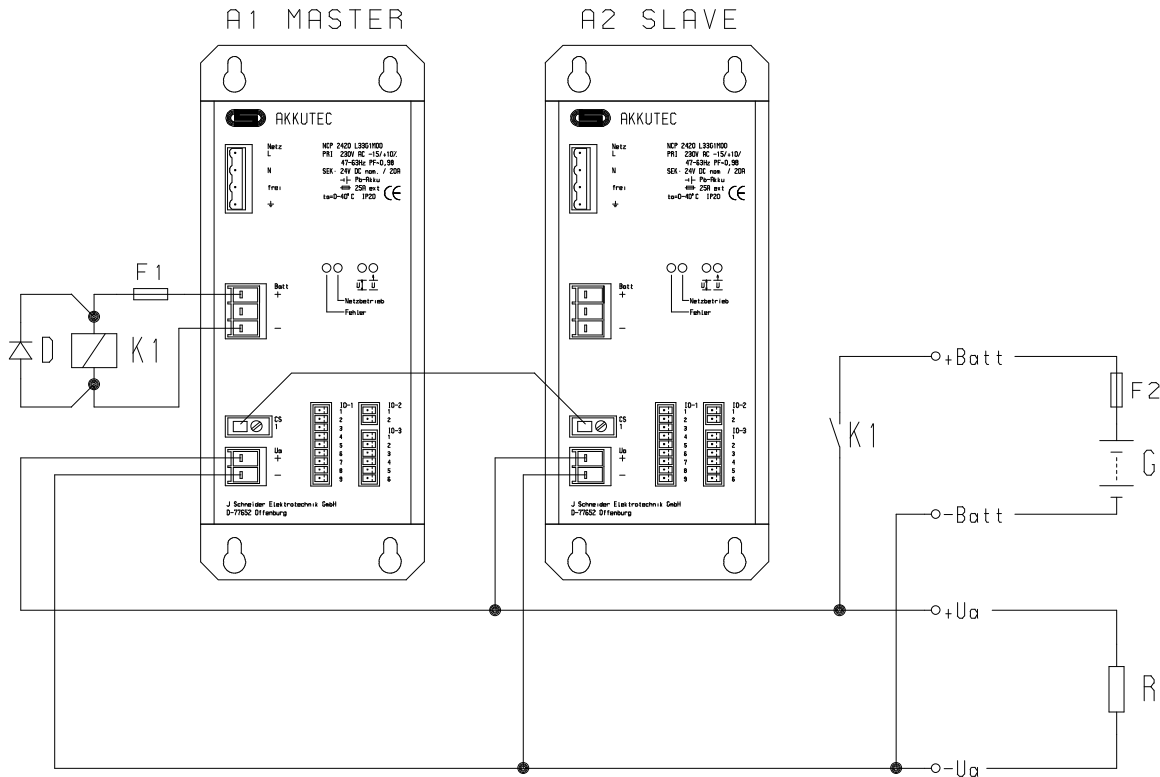

Item Label	Comment
K1	24V DC battery circuit contactor with switching current $I \geq 30A$ DC
D	Free-wheeling diode for battery circuit contactor Attention! Never operate the contactor without a free-wheeling diode! Operation without a free-wheeling diode can result in irreparable damage to the AKKUTEC module!
F1	Fuse protection for battery circuit contactor
F2	Battery circuit protection Attention! The protection components (overload and short circuit protection!) are to be installed as close as possible to the set of batteries for safety reasons
G	Backup battery
A1	AKKUTEC module with standard parameter settings. The complete sampling of the signal inputs and outputs is performed via the master module. (See also Section 3.4) For the connections for the Control and Display Panel, please refer to the appropriate handbook!
A2	AKKUTEC module with special parameter settings as 'Slave Module'. The centralised fault indication signal from the slave module should be evaluated separately. (Selective fault localisation)
R	Loads



In the case of the master-slave configuration, the internal battery reverse pole connection protection is ineffective. Reverse connection of the battery results, unavoidably, in damage to the loads and the **AKKUTEC units!**

F

To exploit the maximum effectiveness from the active current distribution, the “-Ua cabling” between the two modules should be made as symmetrical as possible (cable length, cable cross-section).

13.2 Example Circuit for Redundant Operation (Increase in the System Reliability)

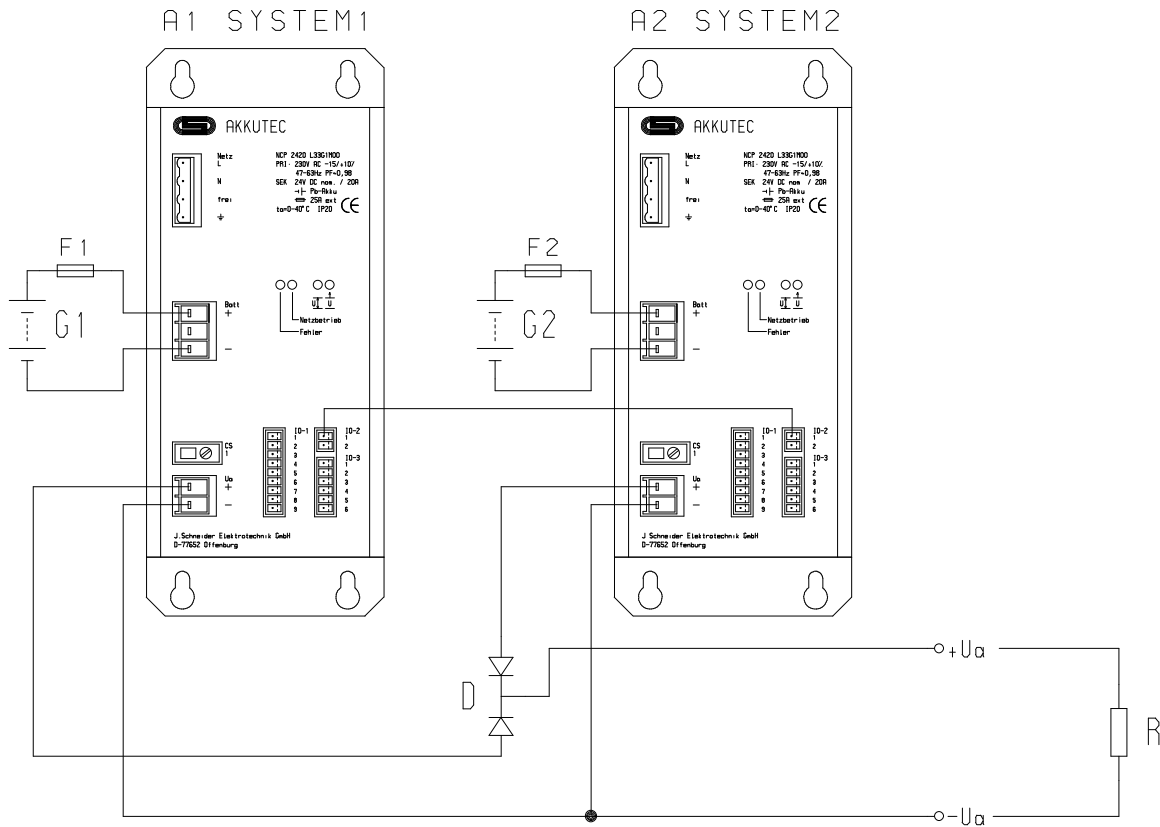

In the case of overload, the DC output current comprises the maximum charging rectifier current as well as the current from the battery. To prevent overload of the DC output circuit, the circuit is to be protected externally! (Value see Section 3.1)

The connections labelled 2 on the IO-2 interface are connected internally with U_a-. To avoid the creation of earth loops, the connections labelled 2 on IO-2 must not be connected together! A connection here can result in damage to the AKKUTEK units!

Component Label	Comment
F1 / F2	Protection of the battery circuit 1 and battery circuit 2 Attention! The protection components (overload and short circuit protection!) are to be installed as close as possible to the set of batteries for safety reasons!
G1 / G2	Backup batteries
D	Decoupling diode module Attention! The decoupling diode module must be designed for the sum of both AKKUTEK output currents (10/20 A)! (Overload/short circuit current!)
A1 / A2	AKKUTEK module with special parameter settings as 'Redundant Module 1' (ID code 0) as well as 'Redundant Module 2' (ID code 1) The complete sampling of the signal inputs and outputs is performed separately. (See also Section 3.4) For the connections for the Control and Display Panel, please refer to the appropriate handbook!
R	Loads